

DETAIL A  
SCALE 1 : 5

ITEM NO.	PART NUMBER	DESCRIPTION	QTY.
1	SHS Base	25x25x1.6 SHS Base	1
2	Sheet Metal Base	1.2mm Black Sheet	1
3	End Hoops	50x3 FL Bar	2
4	Scroll	25x3 FL Bar	52
5	Back Flat bar support	25x10 FL Bar	2

UNLESS OTHERWISE SPECIFIED: DIMENSIONS ARE IN MILLIMETERS		SURFACE FINISH: Painted		DEBUR AND BREAK SHARP EDGES	
TOLERANCES: LINEAR: ±1mm Angular: ±30'		MATERIAL: Low Carbon Steel			
	NAME	SIGNATURE	DATE	CUSTOMER:	
DRAWN BY	RD			TITLE: Wood Holder Assembly	
CHK'D	RD			Part Name: Wood Holder Assembly	
APPV'D	RD			DWG NO. A-101	
REV.	A			DRAWN DATE: 21/05/2017	
DO NOT SCALE DRAWING				A3	
				SCALE: 1:20	
				SHEET 1 OF 5	

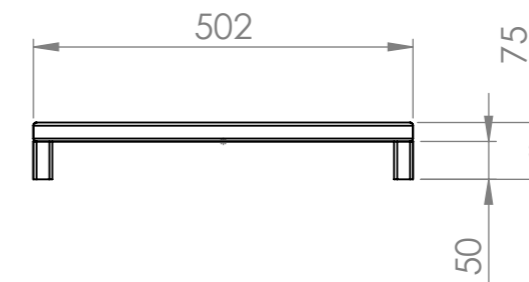
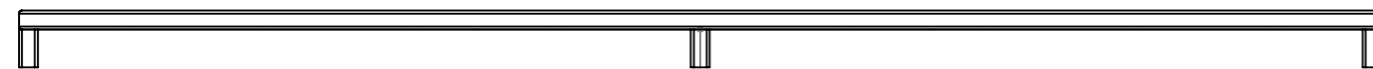
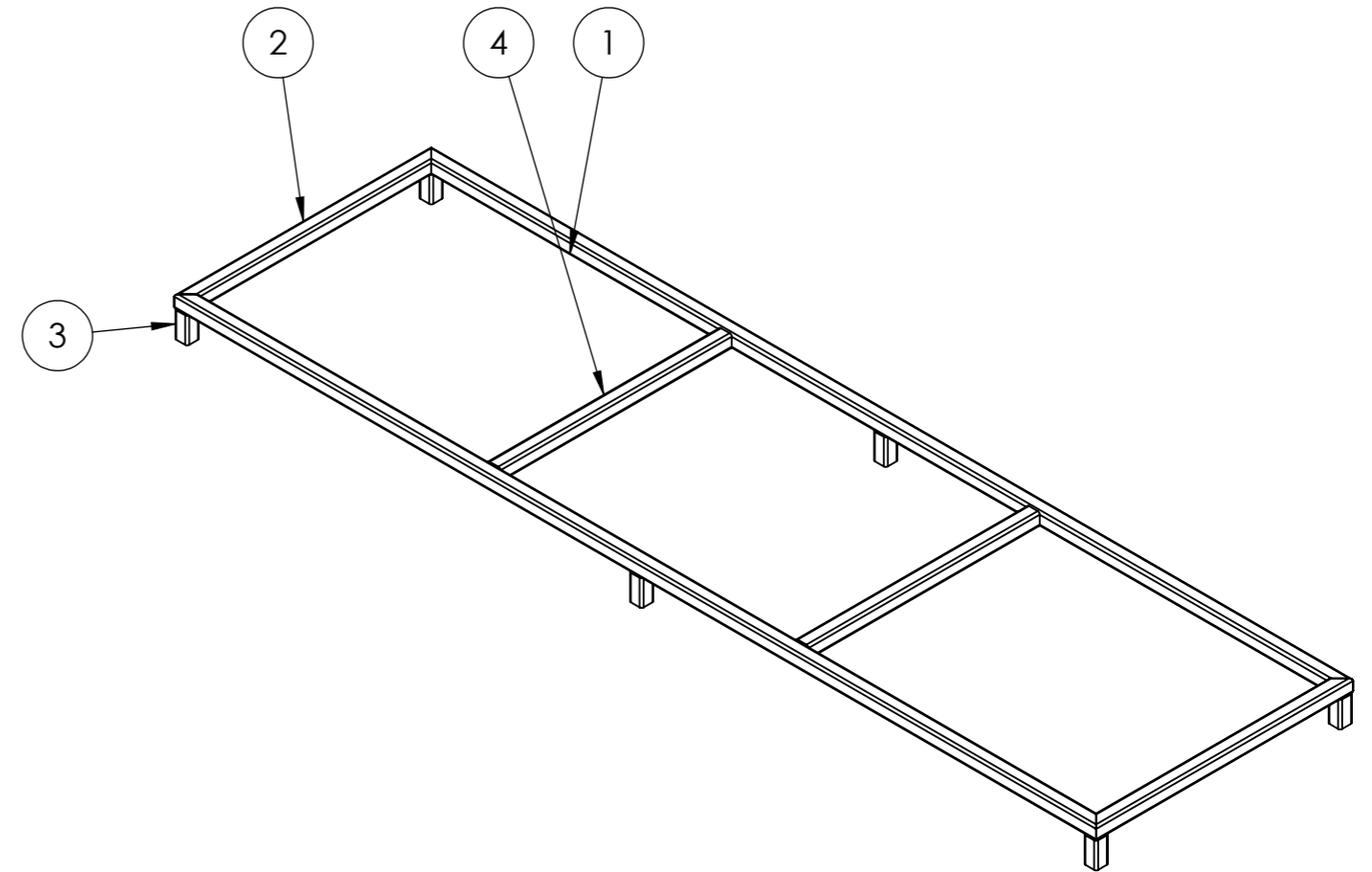
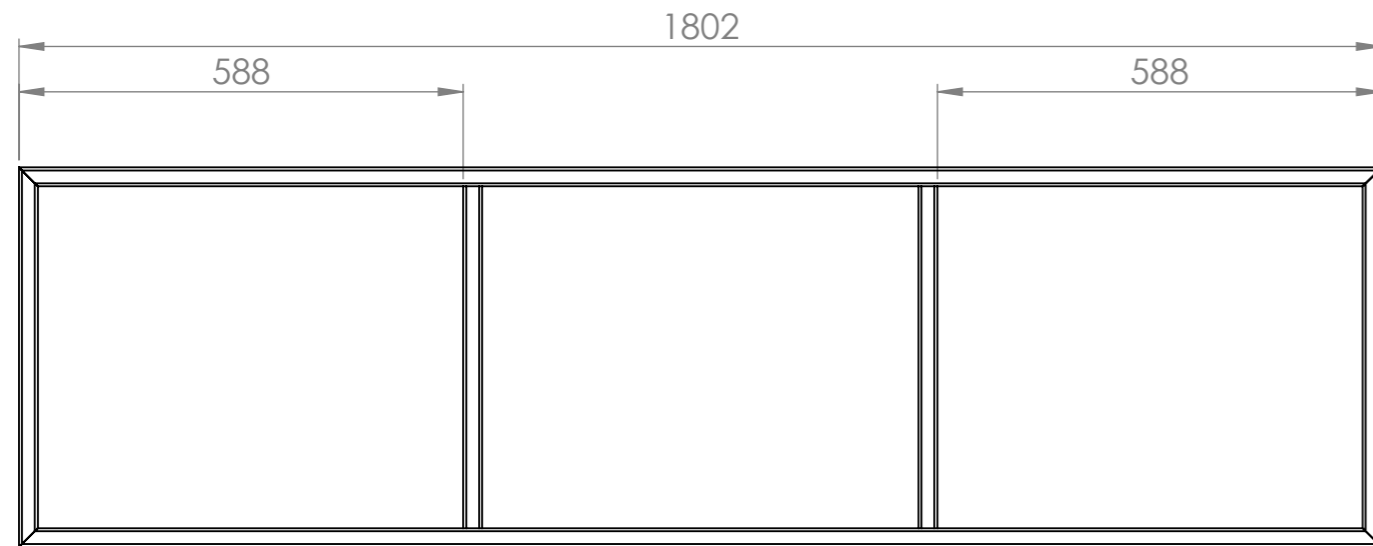

ITEM NO.	QTY.	DESCRIPTION	LENGTH
1	2	25x25x2.0 SHS	1802
2	2	25x25x2.0 SHS	502
3	6	25x25x2.0 SHS	50
4	2	25x25x2.0 SHS	452

UNLESS OTHERWISE SPECIFIED: DIMENSIONS ARE IN MILLIMETERS TOLERANCES: LINEAR: ±1mm Angular: ±30'		SURFACE FINISH: Painted MATERIAL: Low Carbon Steel		DEBUR AND BREAK SHARP EDGES	
DRAWN BY	RD	SIGNATURE		CUSTOMER:	
CHK'D	RD			TITLE: Wood Holder Assembly	
APPV'D	RD			Part Name: SHS Base	
REV.	A			DWG NO. A-102	DRAWN DATE: 21/05/2017
DO NOT SCALE DRAWING				SCALE: 1:10	A3
				SHEET 2 OF 5	

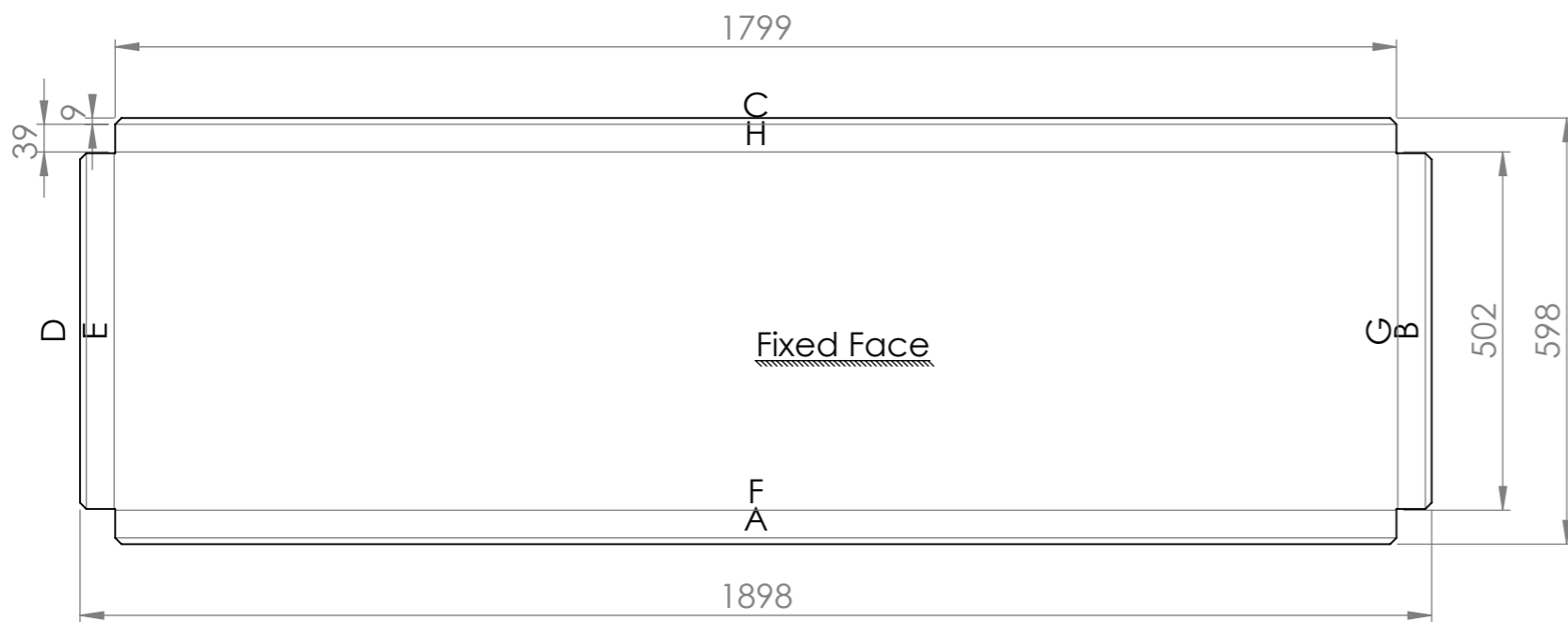
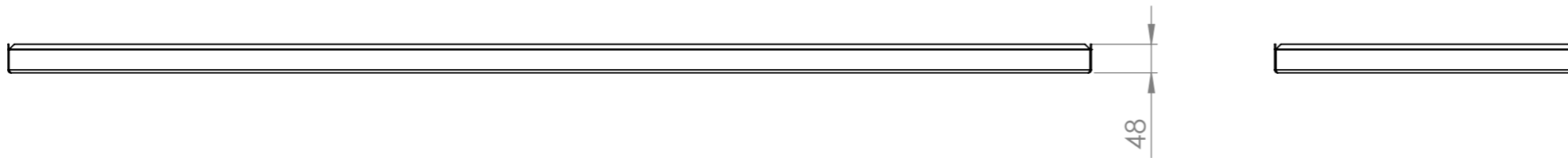
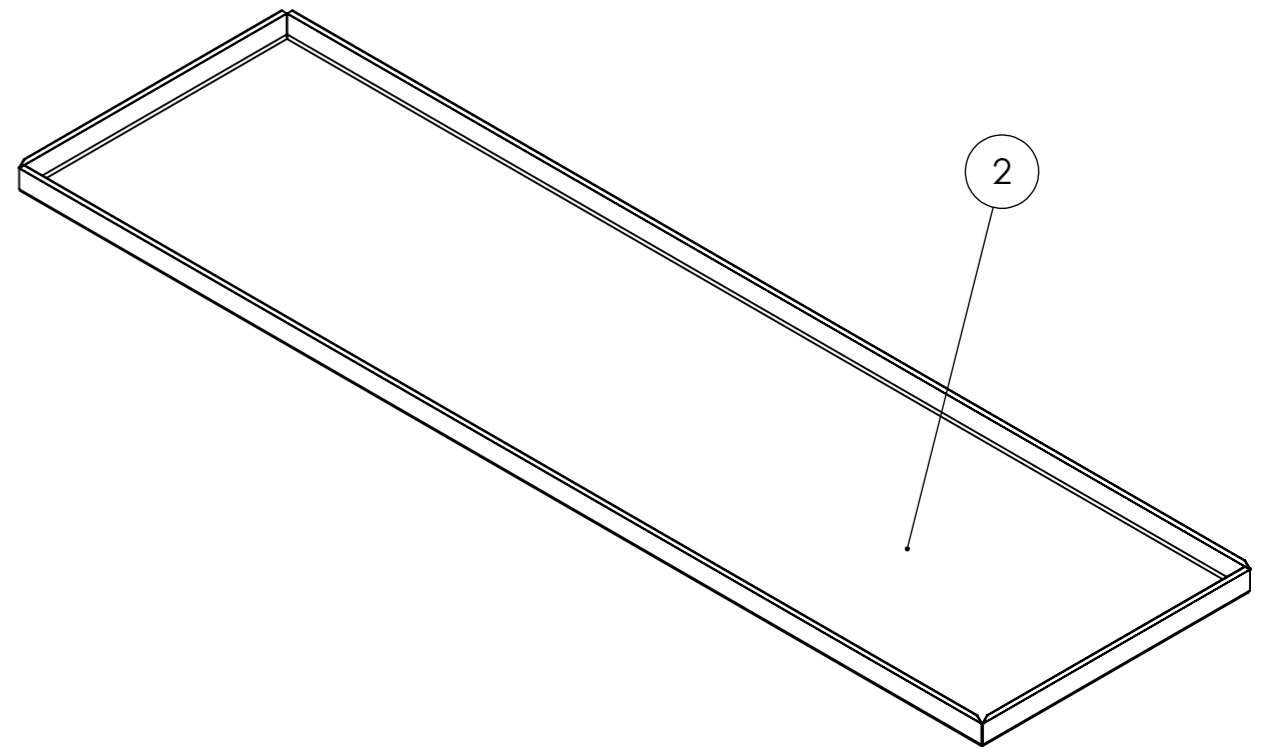
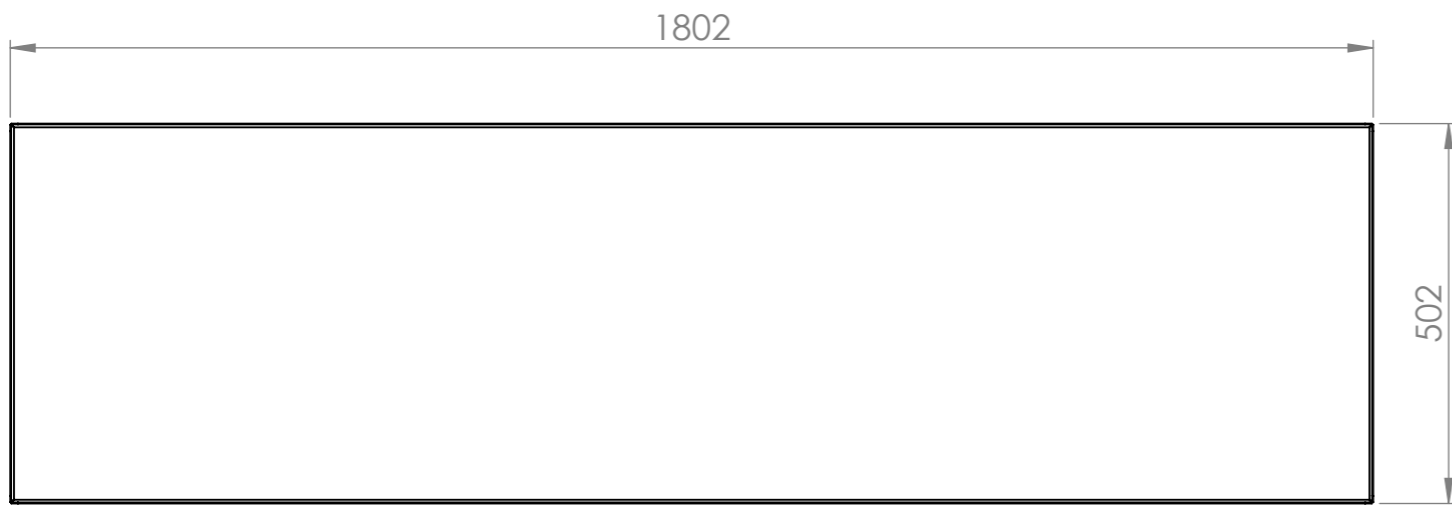

Tag	Direction	Angle	Inner Radius
A	UP	180°	0.05
B	UP	180°	0.05
C	UP	180°	0.05
D	UP	180°	0.05
E	UP	90°	3.75
F	UP	90°	3.75
G	UP	90°	3.75
H	UP	90°	3.75

UNLESS OTHERWISE SPECIFIED: DIMENSIONS ARE IN MILLIMETERS		SURFACE FINISH: Painted		DEBUR AND BREAK SHARP EDGES	
TOLERANCES: LINEAR: ±1mm Angular: ±30'		MATERIAL: Low Carbon Steel			
NAME	SIGNATURE	DATE	CUSTOMER:		
DRAWN BY: RD			TITLE: Wood Holder Assembly		
CHK'D: RD			Part Name: 1.2 Sheet Metal Base		
APPV'D: RD					
REV. A					
DO NOT SCALE DRAWING			DWG NO. A-103	DRAWN DATE: 21/05/2017	A3
			SCALE: 1:10	SHEET 3 OF 5	

ITEM NO.	QTY.	DESCRIPTION	Size
2	1	End Hoops	1898 x 598 x 1.2mm

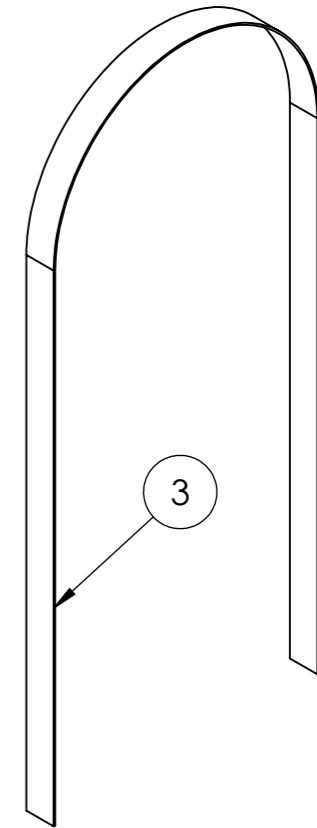
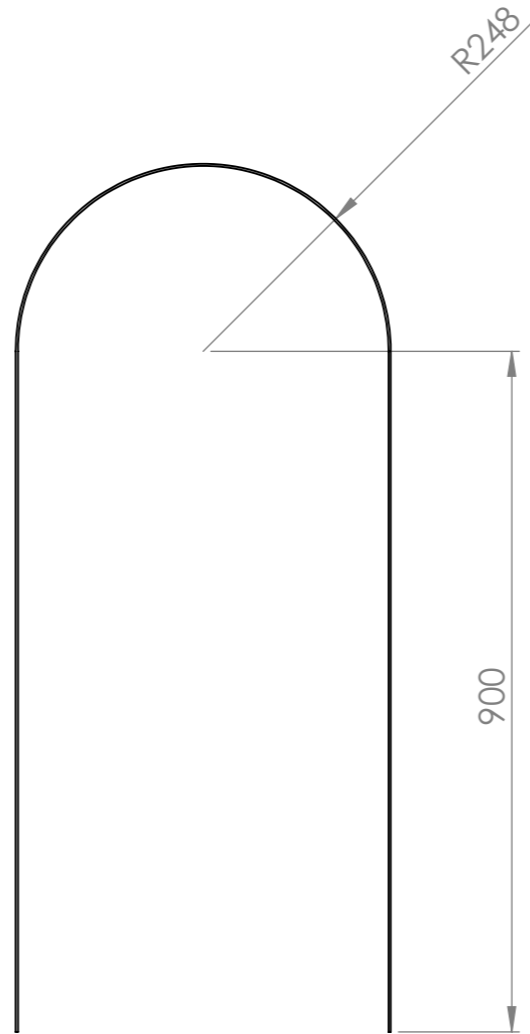
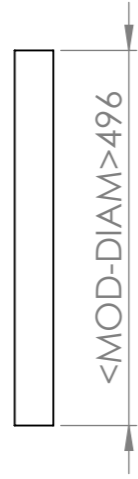

ITEM NO.	QTY.	Description	Length
3	2	50x3 Flat Bar	2575

UNLESS OTHERWISE SPECIFIED: DIMENSIONS ARE IN MILLIMETERS		SURFACE FINISH: Painted		DEBUR AND BREAK SHARP EDGES	
TOLERANCES: LINEAR: ±1mm Angular: ±30'		MATERIAL: Low Carbon Steel			
	NAME	SIGNATURE	DATE	CUSTOMER:	
DRAWN BY	RD			TITLE: Wood Holder Assembly	
CHK'D	RD			Part Name: End Hoops	
APPV'D	RD			DWG NO. A-104	
REV.	A			DRAWN DATE: 21/05/2017	
DO NOT SCALE DRAWING				A3	
				SCALE: 1:10	
				SHEET 4 OF 5	

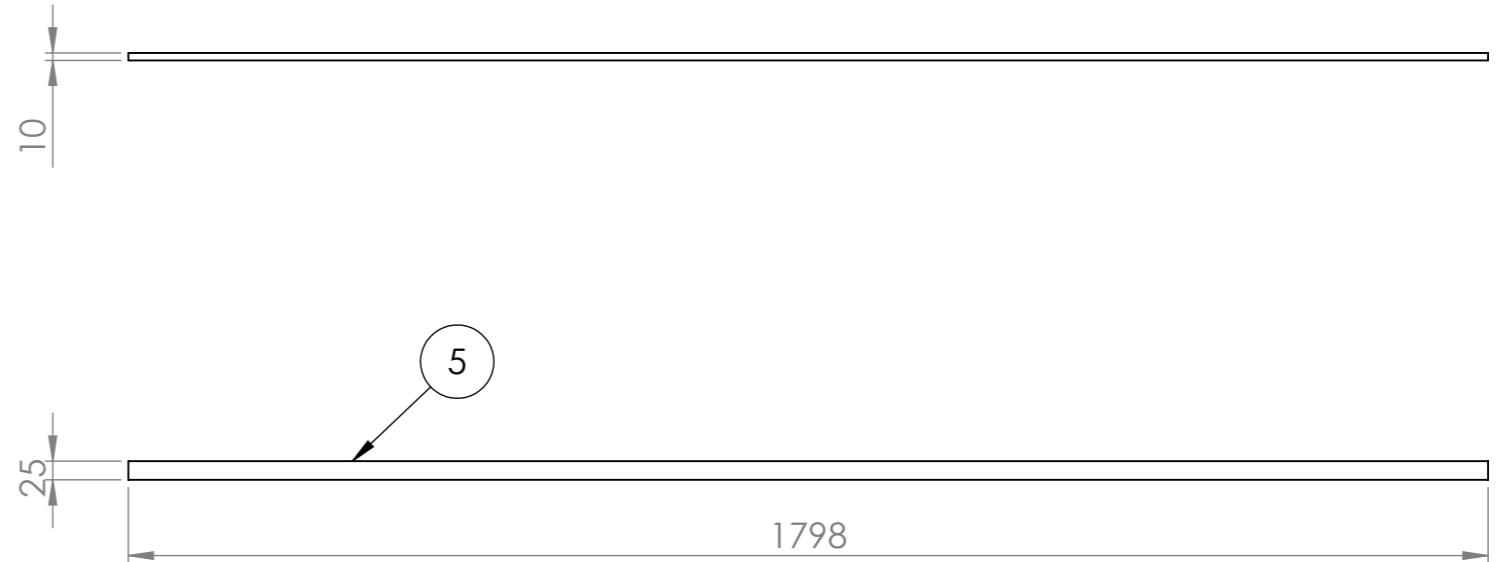
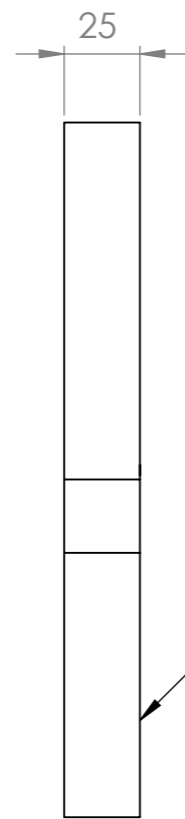
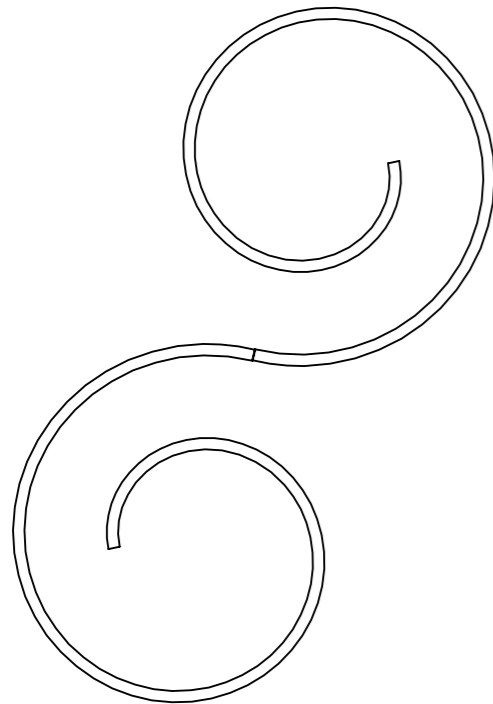
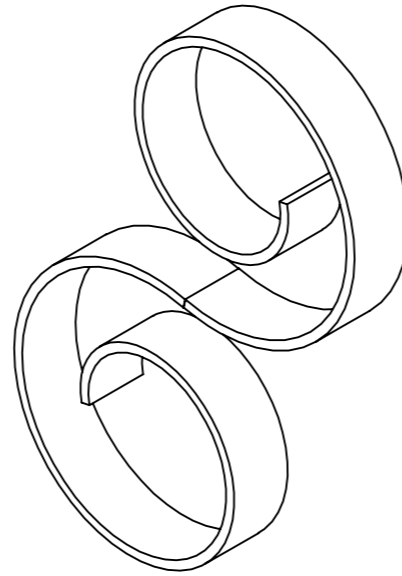

UNLESS OTHERWISE SPECIFIED: DIMENSIONS ARE IN MILLIMETERS		SURFACE FINISH: Painted		DEBUR AND BREAK SHARP EDGES	
TOLERANCES: LINEAR: ±1mm Angular: ±30'		MATERIAL: Low Carbon Steel			
	NAME	SIGNATURE	DATE	CUSTOMER:	
DRAWN BY	RD			TITLE: Wood Holder Assembly	
CHK'D	RD			Part Name: Scroll	
APPV'D	RD			DWG NO. A-105	
REV.	A			DRAWN DATE: 21/05/2017	
DO NOT SCALE DRAWING				A3	
				SCALE: 1:10	
				SHEET 5 OF 5	

ITEM NO.	QTY.	Description	LENGTH
4	52	25x3 Flat Bar	800
5	2	50x10 Flat Bar	1798